

Product data sheet

Specifications



inductive sensor Namur - M5 - L30mm - Sn0.8mm - 7..12VDC - cable 2m

XSMN08122EX

XSMN08122EX has not been replaced. Please contact your customer care center for more information.

⚠ Discontinued

Main

Range of product	Telemecanique Inductive proximity sensors XS
Series name	Application
Sensor type	Inductive proximity sensor
Device application	ATEX dust
Sensor name	XSM
Sensor design	Cylindrical M5
Size	30 mm
Body type	Fixed
Detector flush mounting acceptance	Flush mountable
Material	Metal
Enclosure material	Nickel plated brass
[Sn] nominal sensing distance	0.8 mm
Type of output signal	Discrete
Wiring technique	2-wire
Discrete output function	1 NC
Output circuit type	DC
Discrete output type	Namur
Electrical connection	Cable
Cable length	2 m
[Us] rated supply voltage	7...12 V DC
Switching capacity in mA	<= 1 mA
IP degree of protection	IP67 conforming to IEC 60529

Complementary

Thread type	M5 x 0.5
Detection face	Frontal
Front material	PPS

Sensing range	> 0...2.5 mm
Operating zone	0...0.6 mm
Cable composition	2 x 0.11 mm ²
Wire insulation material	PvR
Maximum residual current	3 mA open state
Switching frequency	<= 1.5 kHz
Marking	II1 D-Ex ia IIIC T85°C Da IP66/67
Threaded length	30 mm
Length	30 mm

Environment

Environmental characteristic	Hazardous location
Standards	EN/IEC 60079-0 EN/IEC 60079-11
Directives	94/9/EC - ATEX directive
Product certifications	INERIS 04ATEX0016X
Ambient air temperature for operation	-20...60 °C
Dust zone	Zone 20

Packing Units

Package 1 Weight	0.042 kg
Package 1 Height	0.300 dm
Package 1 width	0.400 dm
Package 1 Length	1.400 dm

Contractual warranty

Warranty	18 months
-----------------	-----------

Dimensions

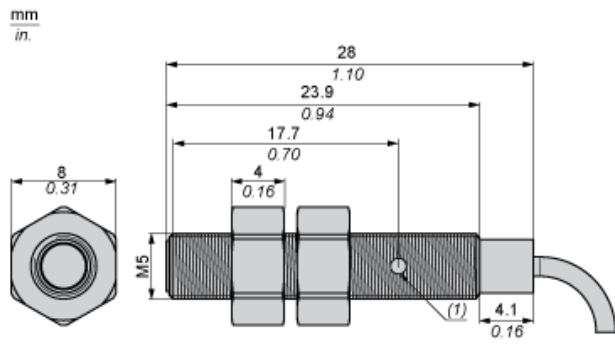

(1) LED

Minimum Mounting Distances in mm

Side by side

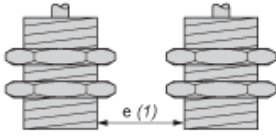

$e (1) \geq 2 \text{ mm}/0.79 \text{ in.}$

Face to face

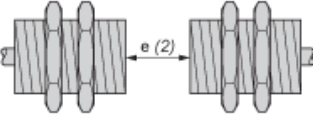

$e (2) \geq 12 \text{ mm}/0.47 \text{ in.}$

Facing a metal object

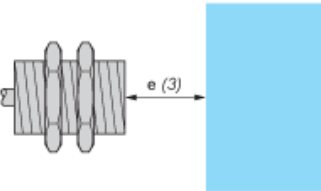

$e (3) \geq 3 \text{ mm}/0.12 \text{ in.}$

Mounted in a metal support

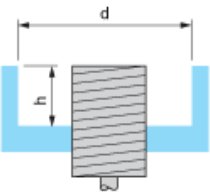

$d \geq 5 \text{ mm}/0.17 \text{ in.}$

$h \geq 0 \text{ mm}/0 \text{ in.}$

Tightening torque : 1.6 N.m. (values obtained with washers mounted)

Mounting

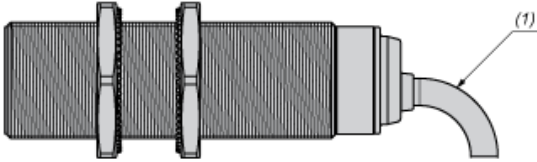

(1) Bending cable: 4 x external cable diameter

Performance Curves

Standard Steel Target (mm) : 5x5x1

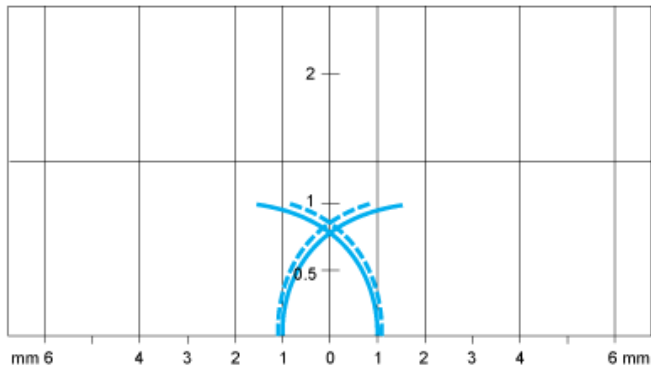

- Pick-up points
- - - - Drop-out points (object approaching from the side)
- (y)** Sensing distance in mm